

HONDA WB20X, WB30X

OWNER'S MANUAL

Thank you for purchasing a Honda water pump.

This manual covers the operation and maintenance of Honda water pump: WB20X/WB30X

All information in this publication is based on the latest product information available at the time of approval for printing.

Honda Motor Co., Ltd. reserves the right to make changes at any time without notice and without incurring any obligation.

No part of this publication may be reproduced without written permission.

This manual should be considered a permanent part of the pump and should remain with the pump if it is resold.

The illustrations in this manual are based on: WB20X

Pay special attention to statements preceded by the following words:

▲WARNING Indicates a strong possibility of severe personal injury or death if instructions are not followed.

CAUTION: Indicates a possibility of equipment or property damage if instructions are not followed.

NOTE: Gives helpful information.

If a problem should arise, or if you have any questions about the pump, consult an authorized Honda dealer.

▲WARNING

This Honda water pump is designed to give safe and dependable service if operated according to instructions. Read and understand the Owner's Manual before operating the pump. Failure to do so could result in personal injury or equipment damage.

- The illustration may vary according to the type.

CONTENTS

1. SAFETY INSTRUCTION	3
2. SAFETY LABEL LOCATIONS	5
CE mark location	6
3. COMPONENT IDENTIFICATION	7
4. PRE-OPERATION FOR STARTING	9
5. STARTING THE ENGINE	14
● High altitude operation	16
6. OPERATION	17
7. STOPPING THE ENGINE	18
8. MAINTENANCE	19
9. TRANSPORTING/STORAGE	24
10. TROUBLESHOOTING	26
11. SPECIFICATIONS	28
12. MAJOR HONDA DISTRIBUTOR ADDRESSES IN EUROPE	30

1. SAFETY INSTRUCTION

▲WARNING

To ensure safe operation —



- Honda water pump is designed to give safe and dependable service if operated according to instructions.

Read and understand the Owner's Manual before operating the water pump. Failure to do so could result in personal injury or equipment damage.

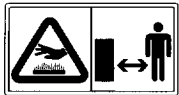

- The muffler becomes very hot during operation and remains hot for a while after stopping the engine. Be careful not to touch the muffler while it is hot. Let the engine cool before storing the water pump indoors.

- The engine exhaust system will be heated during operation and remain hot immediately after stopping the engine.

To prevent scalding, pay attention to the warning marks attached to the water pump.

- Always make a pre-operation inspection (page 9) before you start the engine. You may prevent an accident or equipment damage.
- For safety, never pump flammable or corrosive liquids such as gasoline or acid. Also, to avoid pump corrosion, never pump sea water, chemical solutions, or caustic liquids such as used oil, wine, or milk.
- Place the pump on a firm, level surface. If the pump is tilted or overturned, fuel spillage may result.
- To prevent fire hazards and to provide adequate ventilation, keep the pump at least 1 meter (3 feet) away from building walls and other equipment during operation. Do not place flammable objects close to the pump.
- Children and pets must be kept away from the area of operation due to a possibility of burns from the hot engine components.
- Know how to stop the pump quickly, and understand the operation of all controls. Never permit anyone to operate the pump without proper instructions.

▲WARNING

To ensure safe operation —

- **Gasoline is extremely flammable and is explosive under certain conditions.**
 - **Refuel in a well-ventilated area with the engine stopped. Do not smoke or allow flames or sparks in the refueling area or where gasoline is stored.**
 - **Do not overfill the tank. After refueling, make sure the tank cap is closed properly and securely.**
- **Be careful not to spill fuel when refueling. Spilled fuel or fuel vapor may ignite. If any fuel is spilled, make sure the area is dry before starting the engine.**
- **Never run the engine in an enclosed or confined area. Exhaust gas contains poisonous carbon monoxide gas; exposure can cause loss of consciousness and may lead to death.**

2. SAFETY LABEL LOCATIONS

[DFE type only]

These labels warn you of potential hazards that can cause serious injury. Read the labels and safety notes and precautions described in this manual carefully.

If a label comes off or becomes hard to read, contact your Honda dealer for a replacement.

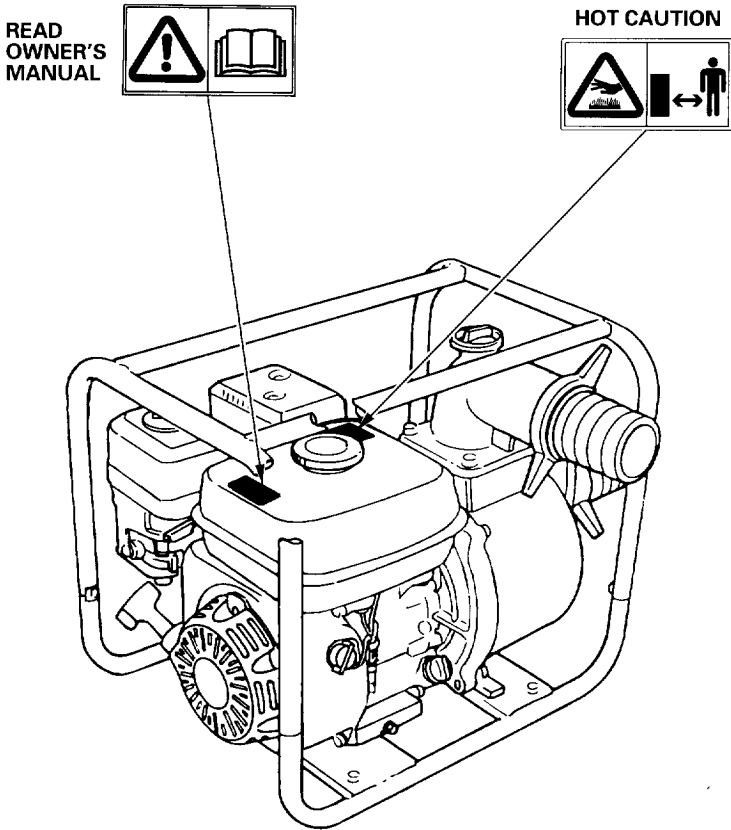

CE mark location.
[DFE type only]

CE MARK

Manufacturer and address

HONDA MOTOR CO, LTD
2-1-1- MINAMI AOYAMA MINATO-KU
TOKYO, JAPAN

CE ■ **WB30X** ■ **199**

■ **4.0 kW 3600 min⁻¹** ■ **30 kg** ← Machine weight (standard specification)

[Example: WB30X CE MARK]

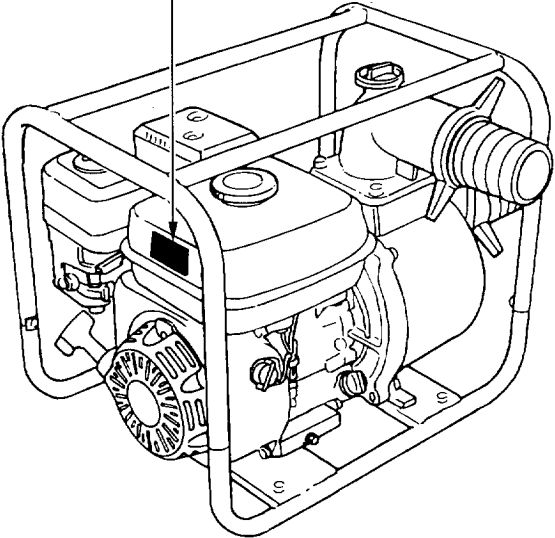

3. COMPONENT IDENTIFICATION

〈WB20X-30X〉

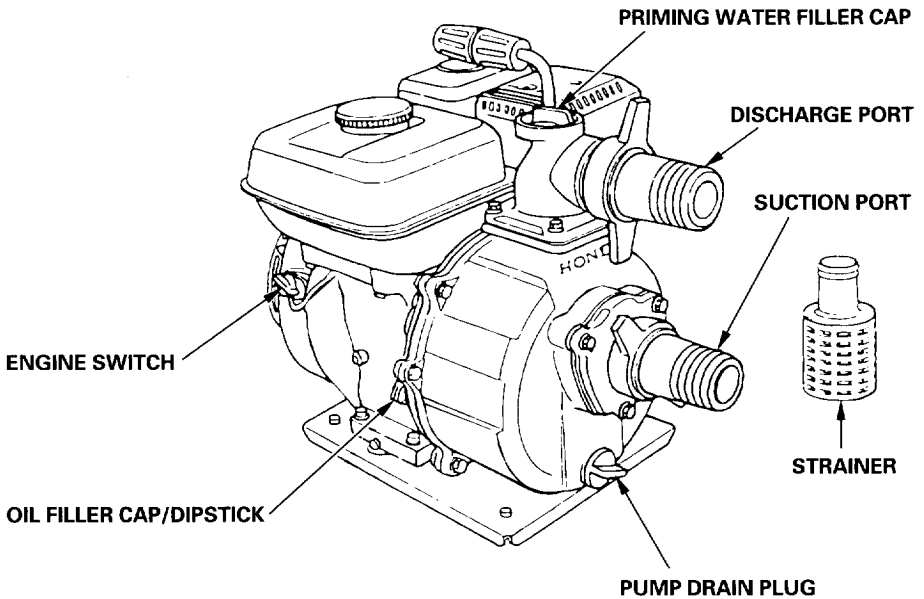
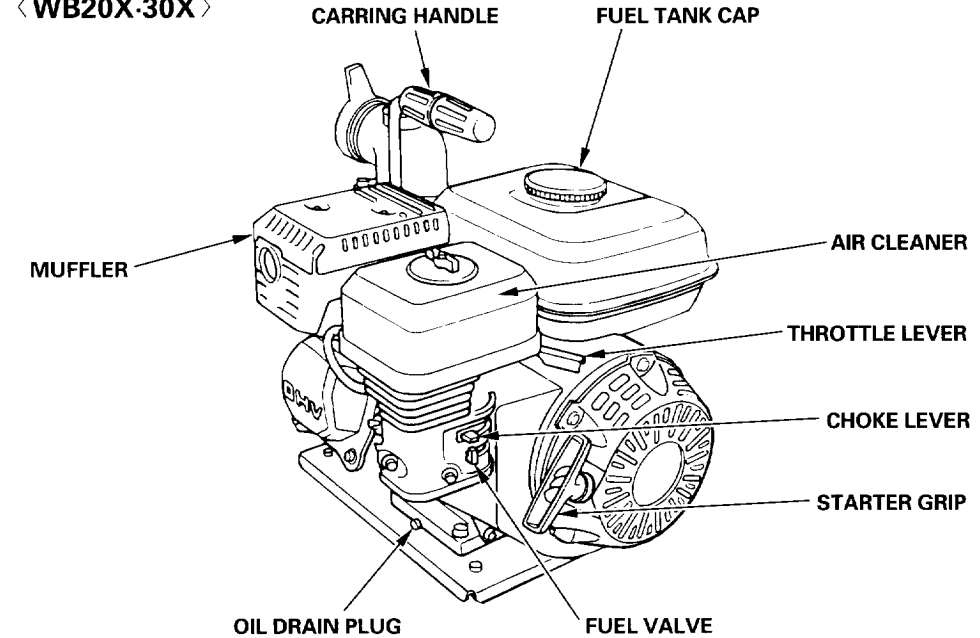

<WB30X> DF type

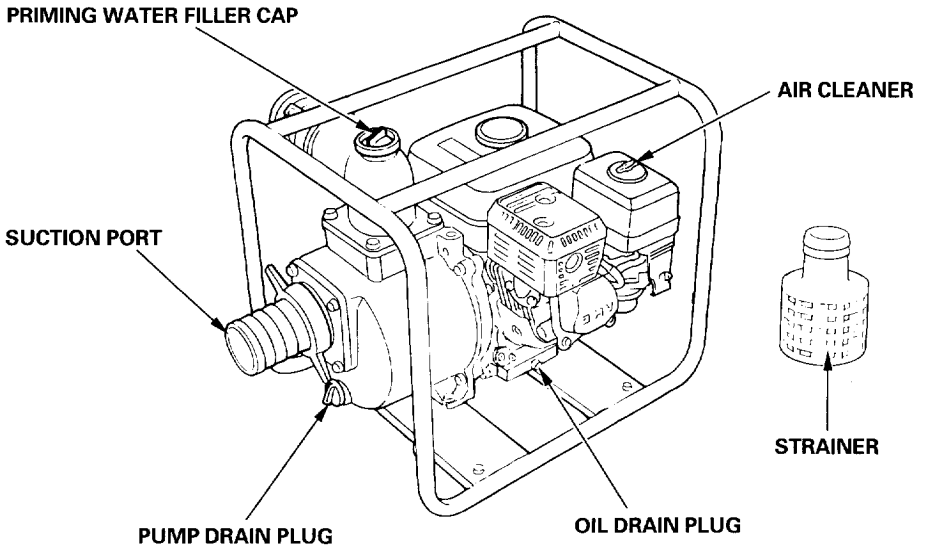
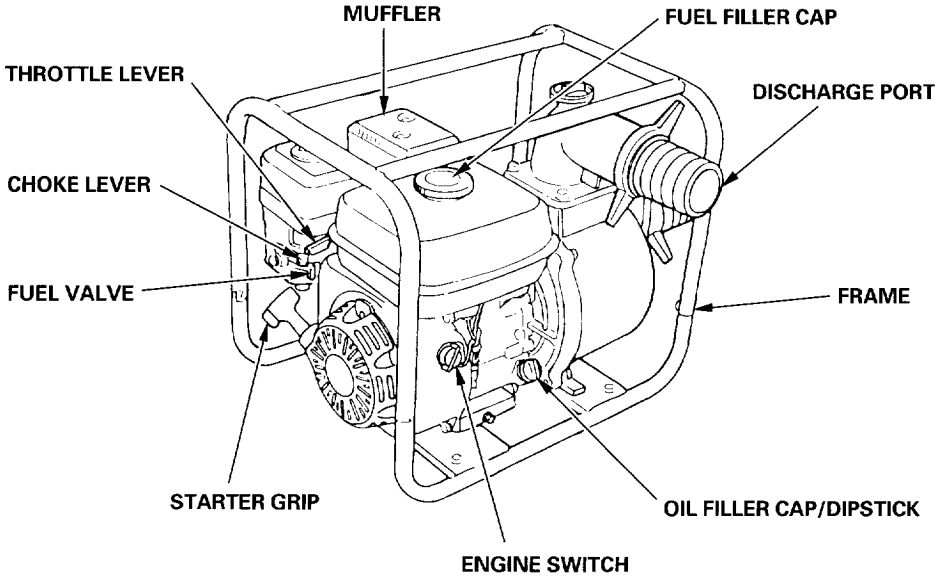

4. PRE-OPERATION FOR STARTING

1. Connect the suction hose.

Use commercially available hose, hose connector, and hose bands. The suction hose must be of reinforced, noncollapsible construction. Suction hose length should not be longer than necessary, as pump performance is best when the pump is not far above the water level. Self-priming time is also proportional to hose length. The strainer that is provided with the pump should be attached to the end of the suction hose with a band, as shown.

CAUTION:

Always install the strainer on the end of the suction hose before pumping. The strainer will exclude debris that can cause clogging or impeller damage.

NOTE:

Tighten the hose connector and bands to prevent air leakage and loss of suction. A loosely connected suction hose will reduce pump performance and self-priming ability.

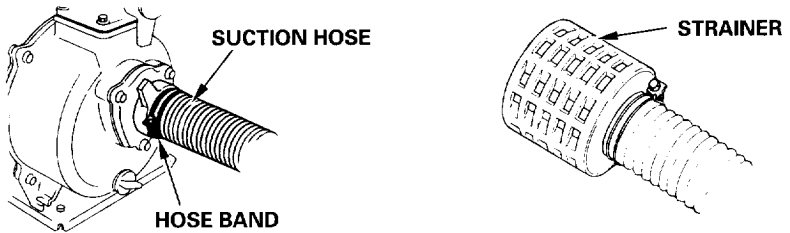

2. Connect the discharge hose.

Use a commercially available hose, hose connector, and hose band. A short, large-diameter hose is most efficient. Long or small-diameter hose increases fluid friction and reduces pump output.

NOTE:

Tighten the hose band securely to prevent the hose from disconnecting under high pressure.

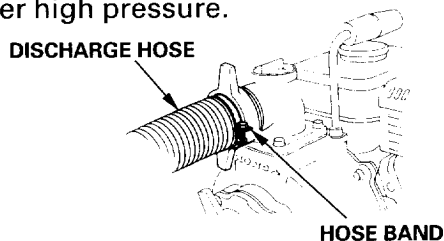

3. Check the engine oil level.

CAUTION:

- Engine oil is a major factor affecting engine performance and service life. Nondetergent or vegetable oils are not recommended.
- Be sure to check the engine on a level surface with the engine stopped.

Use Honda 4-stroke oil, or an equivalent high detergent premium quality motor oil certified to meet or exceed U. S. automobile manufacturer's requirements for Service Classification SG, SF. (motor oils classified SG, SF will show this designation on the container.)

Select the appropriate viscosity for the average temperature in your area.

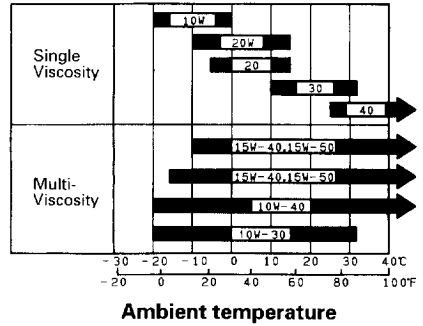

Oil Alert System (where equipped)

The Oil Alert system is designed to prevent engine damage caused by an insufficient amount of oil in the crankcase. Before the oil level in the crankcase can fall below a safe limit, the Oil Alert system will automatically shut down the engine (the engine switch will remain in the ON position).

If the engine stops and will not restart, check the engine oil level before troubleshooting in other areas.

Remove the oil filler cap/dipstick and wipe it clean.

Insert the filler cap/dipstick into the oil filler neck, but do not screw it in. If the level is low, fill to the top of the oil filler neck with the recommended oil.

CAUTION:

Running the engine with insufficient oil can cause serious engine damage.

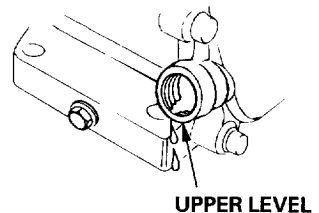
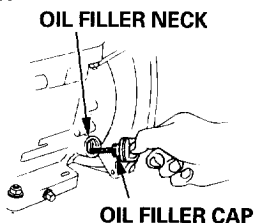

4. Check the fuel level.

Remove the fuel cap and then check the fuel level. Refill the tank if the fuel level is low.

Use automotive gasoline (unleaded or lowleaded is preferred to minimize combustion chamber deposits).

FOR NEW SOUTH WALES ONLY: Use unleaded fuel only.

Never use an oil/gasoline mixture or dirty gasoline. Avoid getting dirt, dust or water in the fuel tank.

▲WARNING

- **Gasoline is extremely flammable and is explosive under certain conditions.**
- **Refuel in a well-ventilated area with the engine stopped. Do not smoke or allow flames or sparks in the refueling area or where gasoline is stored.**
- **Do not overfill the tank (there should be no fuel in the filler neck). After refueling, make sure the tank cap is closed properly and securely.**
- **Be careful not to spill fuel when refueling. Spilled fuel or fuel vapor may ignite. If any fuel is spilled, make sure the area is dry before starting the engine.**
- **Avoid repeated or prolonged contact with skin or breathing of vapor. KEEP OUT OF REACH OF CHILDREN.**

Fuel tank capacity: WB20X... 2.5 ℓ (0.66 US gal , 0.55 Imp gal)
WB30X... 3.6 ℓ (0.95 US gal , 0.79 Imp gal)

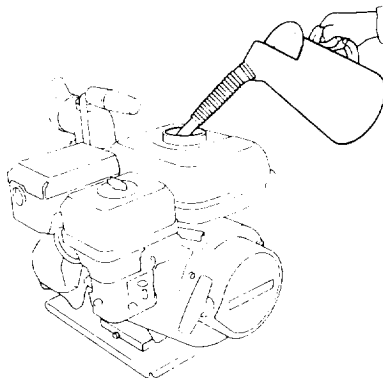

Gasolines containing alcohol

If you decide to use a gasoline containing alcohol (gasohol), be sure it's octane rating is at least as high as that recommended by Honda. There are two types of "gasohol": one containing ethanol, and the other containing methanol. Do not use gasohol that contains more than 10% ethanol. Do not use gasoline containing methanol (methyl or wood alcohol) that does not also contain cosolvents and corrosion inhibitors for methanol. Never use gasoline containing more than 5% methanol, even if it has cosolvents and corrosion inhibitors.

NOTE:

- Fuel system damage or engine performance problems resulting from the use of fuels that contain alcohol is not covered under the warranty. Honda cannot endorse the use of fuels containing methanol since evidence of their suitability is as yet incomplete.
- Before buying fuel from an unfamiliar station, try to find out if the fuel contains alcohol, if it does, confirm the type and percentage of alcohol used. If you notice any undesirable operating symptoms while using a gasoline that contains alcohol, or one that you think contains alcohol, switch to a gasoline that you know does not contain alcohol.

5. Check the air cleaner element.

Remove the wing nut, washer and air cleaner cover. Check the element for dirt or obstruction. Clean the element if necessary (see page 21).

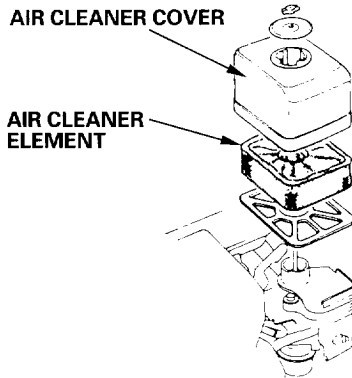

CAUTION:

Never run the engine without the air cleaner. Rapid engine wear will result from contaminants, such as dust and dirt, being drawn through the carburetor, into the engine.

6. Check the priming water.

The pump chamber should be primed with full of water before operating.

CAUTION:

Never attempt to operate the pump without priming water or the pump will overheat. Extended dry operation will destroy the pump seal. If the unit has been operated dry, stop the engine immediately and allow the pump to cool before adding priming water.

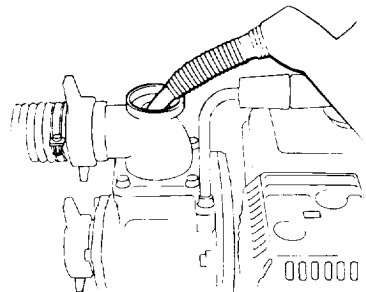
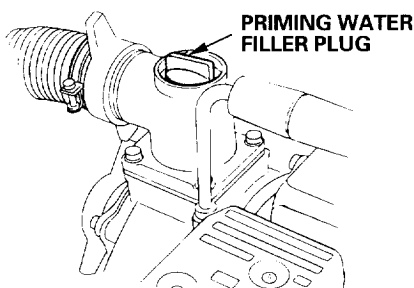

5. STARTING THE ENGINE

1. Turn the fuel valve ON.
2. Close the choke lever.

NOTE:

Do not use the choke if the engine is warm or the ambient temperature is high.

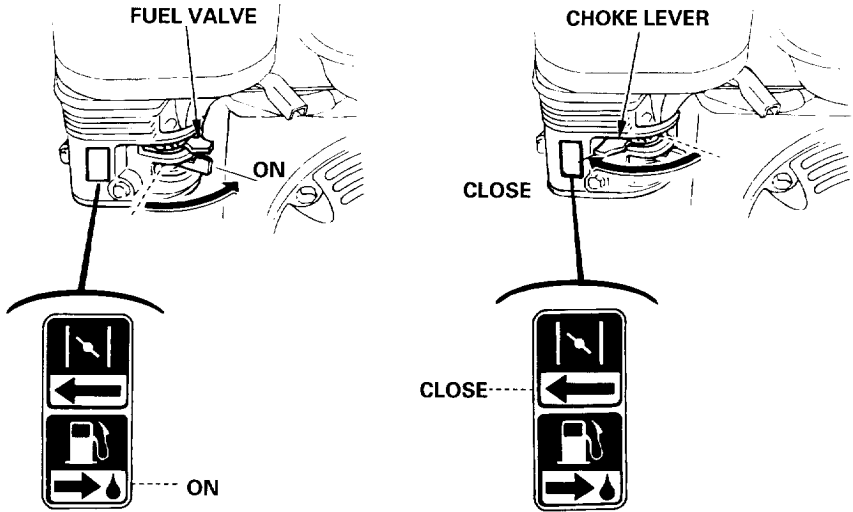

3. Turn the engine switch to the ON position.

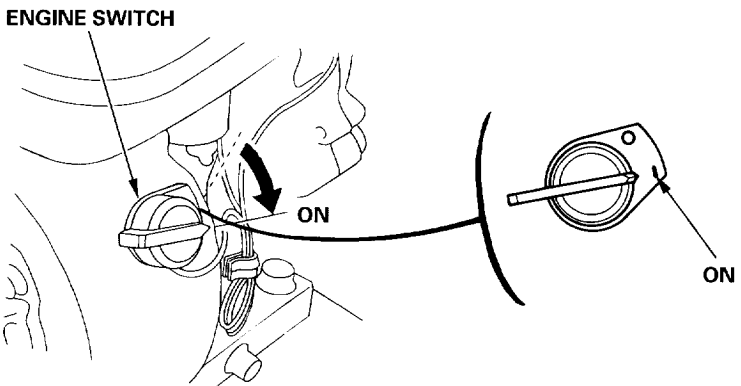

4. Move the throttle lever slightly to the left.

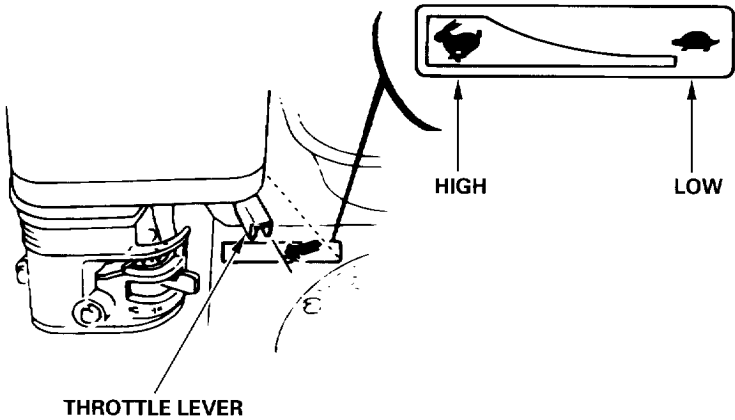

5. Pull the starter grip lightly until resistance is felt, then pull it briskly.

CAUTION:

Do not allow the starter grip to snap back against the engine. Return it gently to prevent damage to the starter.

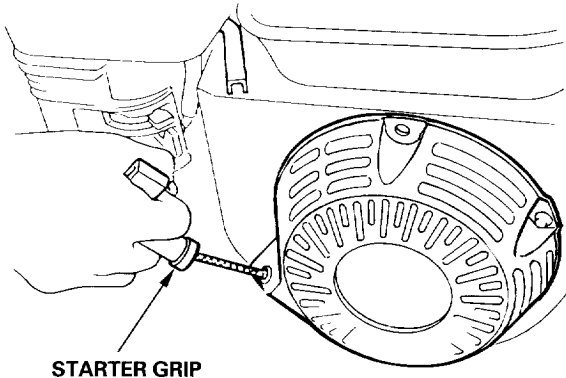

● High altitude operation

At high altitude, the standard carburetor air-fuel mixture will be excessively rich. Performance will decrease, and fuel consumption will increase.

High altitude performance can be improved by installing a smaller diameter main fuel jet in the carburetor and readjusting the pilot screw. If you always operate the pump at altitudes higher than 1,830 m (6,000 feet) above sea level, have your authorized Honda dealer perform these carburetor modifications.

Even with suitable carburetor jetting, engine horsepower will decrease approximately 3.5 % for each 305 m (1,000 foot) increase in altitude. The effect of altitude on horsepower will be greater than this if no carburetor modification is made.

CAUTION:

Operation of the pump at an altitude lower than the carburetor is jetted for may result in reduced performance, overheating, and serious engine damage caused by an excessively lean air/fuel mixture.

6. OPERATION

1. As the engine warms up, gradually open the choke.

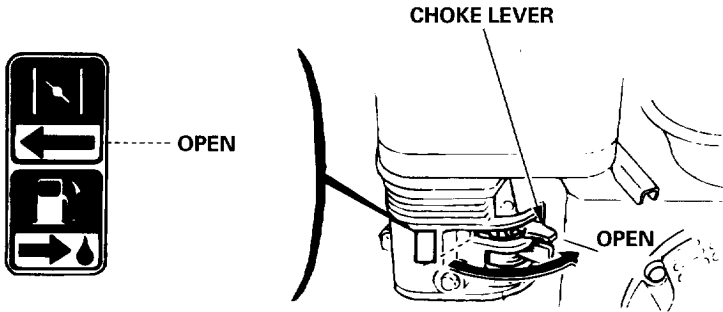

2. Set the throttle at the desired speed.

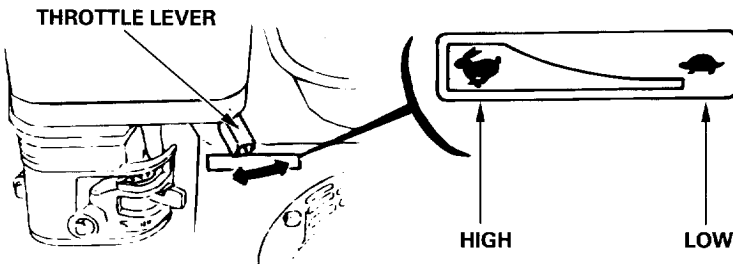

7. STOPPING THE ENGINE

1. Move the throttle lever fully to the right.
2. Turn the engine switch to the OFF position.

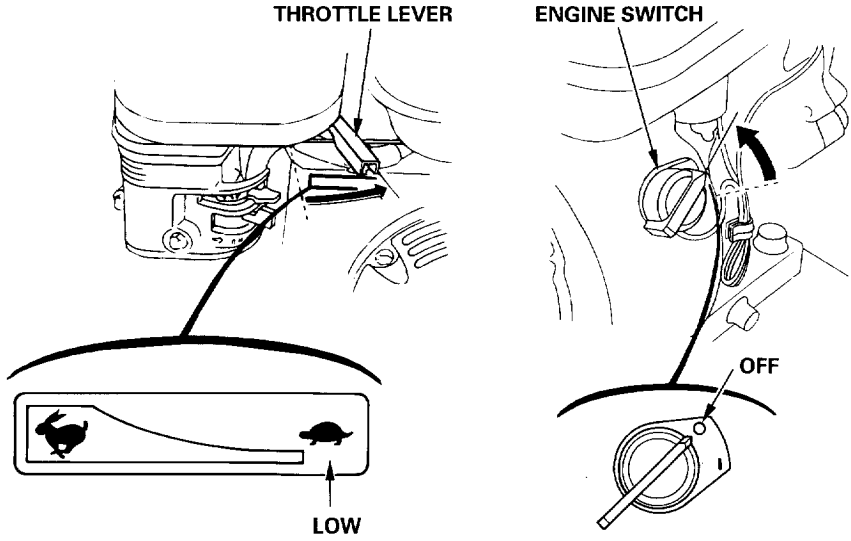

3. Turn the fuel valve OFF.

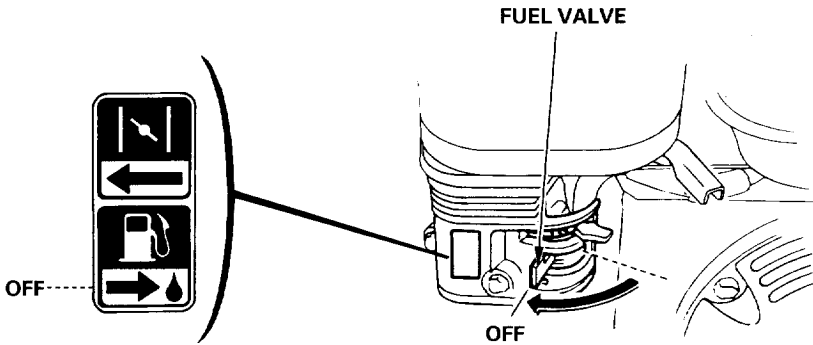

NOTE:

To stop the engine in an emergency, turn the engine switch to the OFF position.

8. MAINTENANCE

Periodic inspection and adjustment of the pump are essential if high level performance is to be maintained. Regular maintenance will also help to extend service life. The required service intervals and the kind of maintenance to be performed are described in the table below.

▲WARNING

Shut off the engine before performing any maintenance. If the engine must be run, make sure the area is well-ventilated. The exhaust contains poisonous carbon monoxide gas; exposure can cause loss of consciousness and may lead to death.

CAUTION:

- If the pump has been used with sea water, etc., pump clean, fresh water immediately afterward to reduce corrosion or remove sediment.
- Use genuine Honda parts or their equivalent for maintenance or repair. Replacement parts which are not of equivalent quality may damage the pump.

Maintenance schedule

REGULAR SERVICE PERIOD		Dairy	First month or 20 Hrs.	Every 3 months or 50 Hrs.	Every 6 months or 100 Hrs.	Every year or 300 Hrs.
ITEM	Perform at every indicated month or operating hour interval, whichever comes first.					
Engine oil	Inspection	○				
	Change		○		○	
Air cleaner element	Inspection	○				
	Cleaning			○(1)		
Spark plug maintenance					○	
Tappet clearance adjustment						○(2)
Combustion chamber cleaning						○(2)
Fuel tank cleaning						○(2)
Spark arrester		Clean every 100 operating hours				
Fuel line		Replace every 2 years.				
Impeller inspection						○(2)
Casing cover inspection						○(2)
Inlet valve inspection						○(2)

NOTE: (1) Service more frequently when used in dusty areas.

(2) These items should be serviced by an authorized Honda dealer, unless the owner has the proper tools and is mechanically proficient. See the Honda Shop Manual.

1. Changing oil

Drain the oil while the engine is still warm to assure rapid and complete draining.

1. Remove the oil filler cap/dipstick and the drain plug, then drain the oil.
2. Reinstall the drain plug and tighten securely.
3. Refill with the recommended oil (see page 10) to the specified level.

OIL CAPACITY: 0.6 ℓ (0.6 US qt , 0.5 Imp qt)

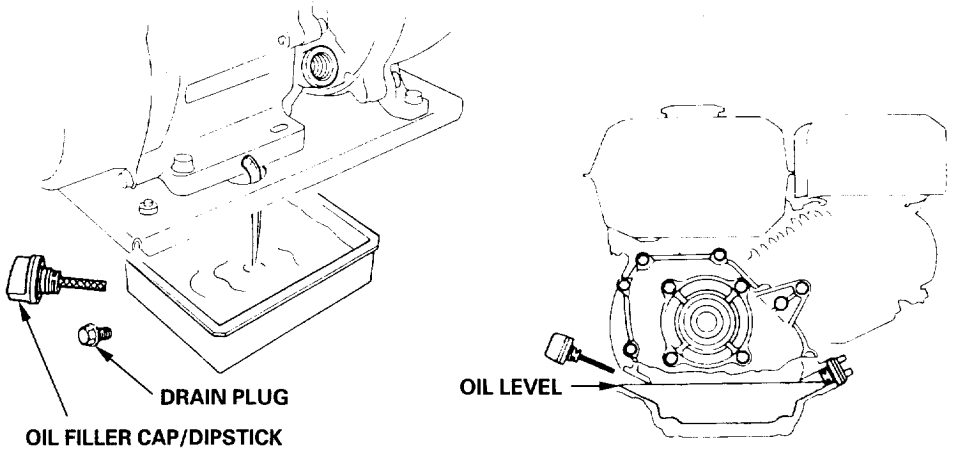

Wash your hands with soap and water after handling used oil.

NOTE:

Please dispose of used motor oil in a manner that is compatible with the environment. We suggest you take it in a sealed container to your local service station for reclamation. Do not throw it in the trash or pour it on the ground.

2. Air cleaner service

A dirty air cleaner will restrict air flow to the carburetor. To prevent carburetor malfunction, service the air cleaner regularly. Service more frequently when operating the pump in extremely dusty areas.

▲WARNING

Do not use gasoline or low flash point solvents for cleaning. They are flammable and explosive under certain conditions.

CAUTION:

Never run the pump without the air cleaner. Rapid engine wear will result from contaminants such as dust and dirt being drawn into the engine.

1. Unscrew the wing nut, remove the air cleaner cover and remove the element.
2. Wash the element in a nonflammable or high flash point solvent and dry it thoroughly.
3. Soak the element in clean engine oil and squeeze out the excess oil.
4. Reinstall the air cleaner element and the cover.

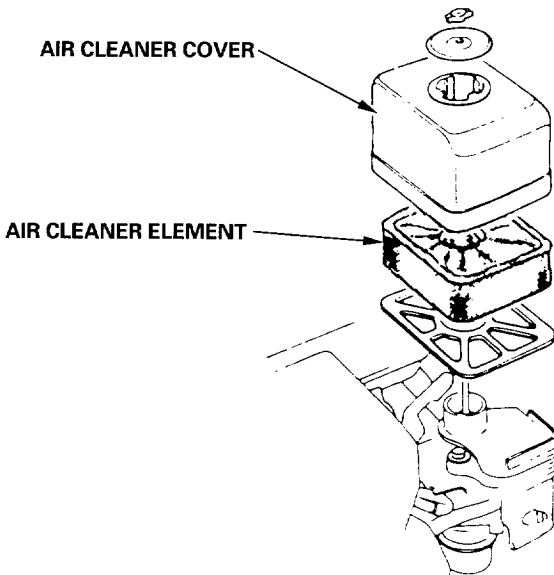

3. Spark plug service

Recommended spark plug: BPR6ES (NGK)
W20EPR-U (NIPPONDENSO)

To ensure proper engine operation, the spark plug must be properly gapped and free of deposits.

1. Remove the spark plug cap.

▲WARNING

If the engine has been running, the muffler will be very hot. Be careful not to touch the muffler.

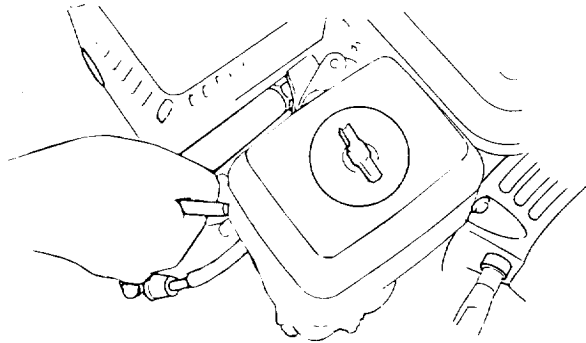

2. Visually inspect the spark plug. Discard the spark plug if there is apparent wear, or if the insulator is cracked or chipped. Clean the spark plug with a wire brush if it is to be reused.
3. Measure the plug gap with a feeler gauge. Correct as necessary by bending the side electrode. The gap should be:
0.70–0.80 mm (0.028–0.031 in)

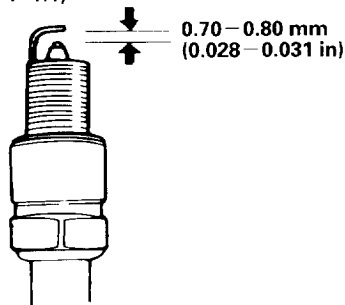

-
4. Check that the spark plug washer is in good condition, and thread the spark plug in by hand to prevent cross-threading.

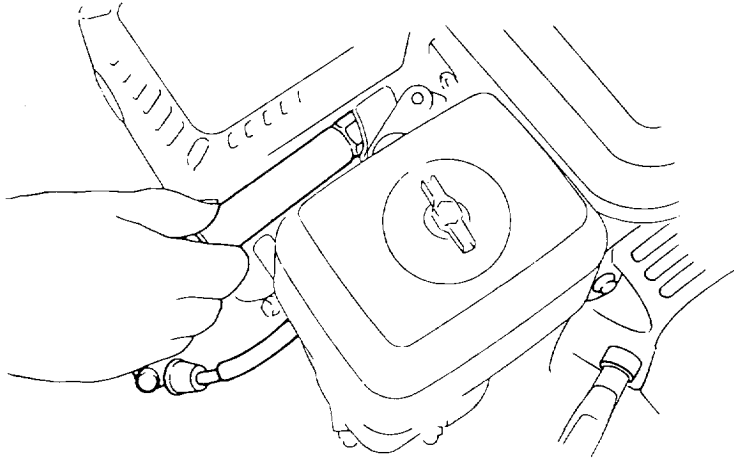

NOTE:

If installing a new spark plug, tighten $1/2$ turn after the spark plug seats to compress the washer. If reinstalling a used spark plug, tighten $1/8$ – $1/4$ turn after the spark plug seats to compress the washer.

CAUTION:

The spark plug must be securely tightened. An improperly tightened plug can become very hot and possibly damage the engine. Never use a spark plug with an improper heat range.

9. TRANSPORTING/STORAGE

▲WARNING

- To avoid severe burns or fire hazards, let the engine cool before transporting the pump or storing it indoors.
- When transporting the pump, turn the fuel valve to the OFF position, and keep the pump level to prevent fuel spillage. Spilled fuel or fuel vapor may ignite.

Before storing the pump for an extended period;

1. Be sure the storage area is free of excessive humidity and dust.
2. Clean the pump interior.....

Sediment will settle in the pump if it has been used in muddy or sandy water, water containing heavy debris.

Pump clean water through the pump before shutting down or impeller may be damaged when restarting. After flushing, remove the pump drain plug, drain as much water as possible from the pump housing and reinstall the plug.

3. Drain the fuel.....

- a. With the fuel valve OFF, remove the drain screw from carburetor float bowl and drain the carburetor. Drain the gasoline into a suitable container.
- b. Turn the fuel valve ON and drain the gasoline in the fuel tank into the suitable container.
- c. Reinstall the carburetor drain screw.

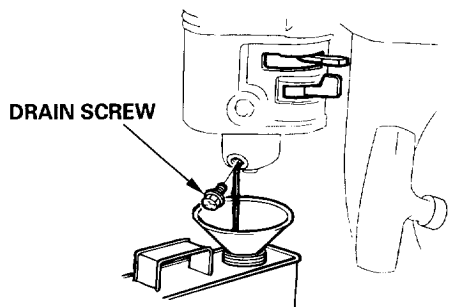
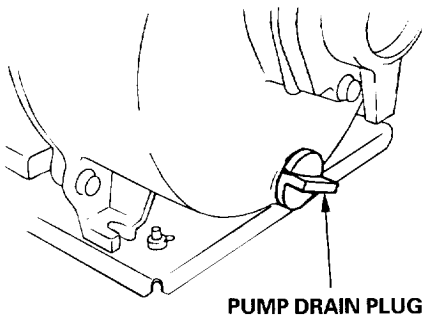

-
4. Change the engine oil.
 5. Remove the spark plug, and pour about a tablespoon of clean engine oil into the cylinder. Crank the engine several revolutions to distribute the oil, then reinstall the spark plug.
 6. Pull the starter grip until resistance is felt: Continue pulling until the notch on the starter pulley aligns with the hole on the recoil starter (see illustration below). At this point, the intake and exhaust valves are closed, and this will help to protect the engine from internal corrosion.

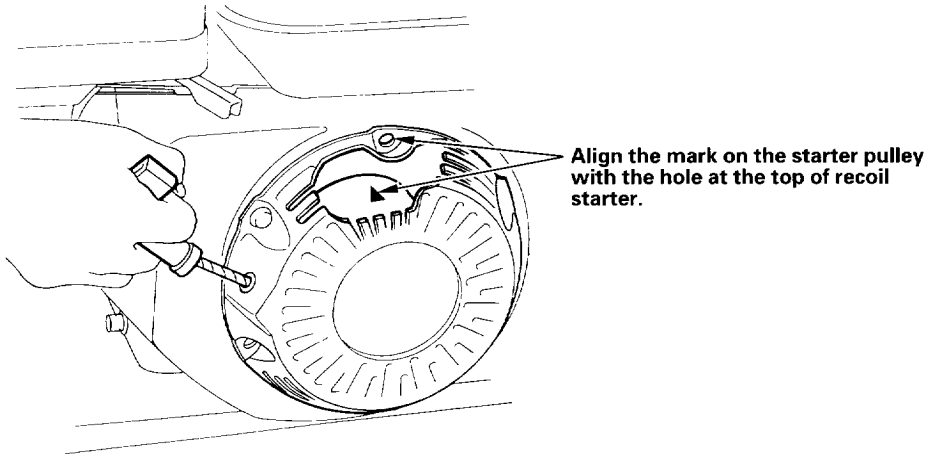

7. Cover the pump to keep out dust.

10. TROUBLESHOOTING

When the engine will not start:

1. Is there enough fuel?
2. Is the fuel valve ON?
3. Is gasoline reaching the carburetor?

To check, loosen the drain screw with the fuel valve ON.

▲WARNING

If any fuel is spilled, make sure the area is dry before testing the spark plug or starting the engine. Spilled fuel or fuel vapor may ignite.

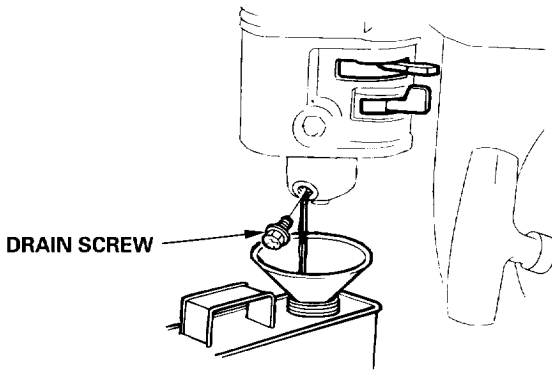

4. Is the engine switch ON?
5. Is there enough oil in the engine?
6. Is there a spark at the spark plug?
 - a. Remove the spark plug cap. Clean any dirt from around the spark plug base, then remove the spark plug.
 - b. Install the spark plug in the plug cap.
 - c. Turn the engine switch ON.
 - d. Grounding the side electrode to any engine ground, pull the recoil starter to see if sparks jump across the gap.
 - e. If there are no sparks, replace the plug.
If OK, try to start the engine according to the instructions.
7. If the engine still does not start, take the pump to an authorized Honda dealer.

When the pump cannot pump the water:

1. Is the pump fully primed?

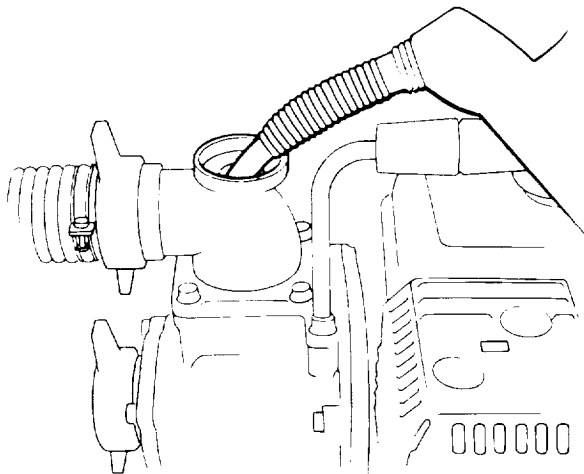

2. Is the strainer clogged?

3. Are the hose bands installed securely?

4. Are the hoses damaged?

5. Is the suction head too high?

6. If the pump still does not operate, take the pump to an authorized Honda dealer.

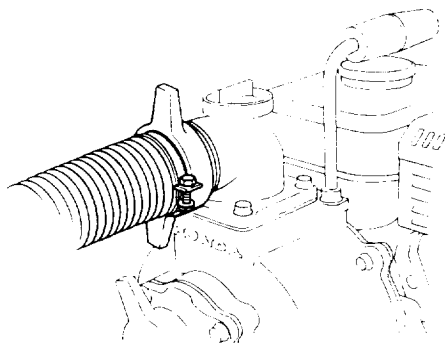
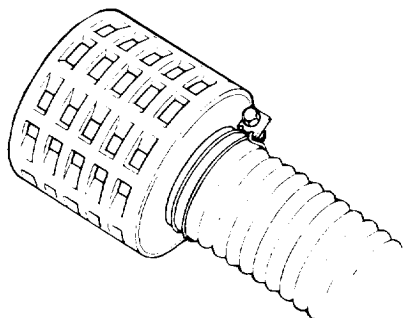

11. SPECIFICATIONS

Model	WB20X
Power product description code	WZAR

Dimensions and Weight

Length	445 mm (17.5 in)
Width	345 mm (13.6 in)
Height	395 mm (15.6 in)
Dry weight	19.5 kg (43.0 lbs)...C, S 20.0 kg (44.1 lbs)...D, DX

Engine

Model	GX120 K1
Engine type	4-stroke, over head valve, 1cylinder
Displacement [Bore × Stroke]	118 cm ³ (7.2 cu-in) 60 x 42 mm (2.4 x 1.7 in)
Max. output	4.0 PS/4,000 rpm
Max. torque	0.75 kg-m (5.0 ft-lb)/2,500 rpm
Cooling system	Forced air
Ignition system	Transistor magneto
PTO shaft rotation	Counterclockwise

Pump

Suction port diameter	50 mm (2.0 in)
Discharge port diameter	50 mm (2.0 in)
Rated revolutions	3,550 rpm
Total head	32 m (105 ft)
Suction head	8 m (26.3 ft)
Capacity	600 ℓ (158.5 US gal , 132.0 Imp gal)/min
Continuous running time	2 h 30 min

Modèle	WB30X
Code de description de produit motorisé	WZAT

Dimensions et poids

Longueur	505 mm	520 mm*
Largeur	400 mm	360 mm*
Hauteur	450 mm	420 mm*
Poids sec	27,0 kg	24,0 kg*

Moteur

Modèle	GX160 K1
Type de moteur	4 temps, soupape en tête, 1 cylindre
Cylindrée [Alésage et course]	163 cm ³ [68 x 45 mm]
Puissance maxi.	5,5 PS/4.000 min ⁻¹ (tr/mn)
Couple maxi.	1,1 kg-m/2.500 min ⁻¹ (tr/mn)
Système de refroidissement	Air forcé
Système d'allumage	Transistor magnétique
Sens de rotation d'arbre PTO	Sens inverse des aiguilles d'une montre

Pompe

Diamètre d'orifice d'aspiration	80 mm
Diamètre d'orifice d'écoulement	80 mm
Révolutions nominales	3.550 min ⁻¹ (tr/mn)
Hauteur totale	28 m
Tête d'aspiration	8 m
Capacité	1.100 ℓ /min
Temps de marche continue	2 h 30 min.

*..... Modèle DF

12. ADRESSES DES PRINCIPAUX CONCESSIONNAIRES HONDA EN EUROPE

NAME OF FIRM (COMPANY)	ADDRESS	TEL: FAX:
Honda (U.K.) Limited	Power Road, Chiswick, London W.4 United Kingdom	Tel: 081-747-1400 Fax: 081-747-3594
Honda France S.A.	Parc d'activités de Pariest B.P. 46, 77312 Marne la Vallée Cedex France	Tel: 1-60-37-30-00 Fax: 1-60-37-33-33
Honda Deutschland GmbH.	Sprendlinger, Landstraße 166 D-63069 Offenbach/Main Germany	Tel: 069-83-09-0 Fax: 069-83-09-519
Honda Belgium H.V.	Wijngaardveld 1, 9300 Aalst Belgium	Tel: 053-725-111 Fax: 053-725-100
Honda Italia Industriale S.P.A.	Via Kenia 72 00144 Roma EUR Italy	Tel: 06-54-7941 Fax: 06-59-20214
Honda (Suisse) S.A.	Route des Moulières 10 Case Postale Ch 1214 Vernier-Geneve, Switzerland	Tel: 022-341-22-00 Fax: 022-341-09-72
Honda Nederland B.V.	Nikkelstraat 17 2984 Ridderkerk Netherlands	Tel: 018-04-57-333 Fax: 018-04-29-075
Honda Austria G.M.B.H.	Honda Strasse 1 A-2351 Wiener Neudorf Austria	Tel: 223-66-900 Fax: 223-66-4130
Honda Power Equipment Sweden A.B.	Ostmästargränd 8 Stockholm-Årsta Sweden	Tel: 08-602-24-60 Fax: 08-722-36-27
Honda Produtos De Força, Portugal, S.A.	Limites do Ral Pavilhão 6 Vila Verde, 2710 Sintra Portugal	Tel: 1-9615729 Fax: 1-9615722
Berema A/S	Berghagan 5, Langhus Box 454, 1401 Ski Norway	Tel: 64-86-05-00 Fax: 64-86-05-49

NAME OF FIRM (COMPANY)	ADDRESS	TEL: FAX:
OY Brandt AB	Tuupakantie 4 SF-01740, Vantaa Finland	Tel: 90-895-501 Fax: 90-878-5276
Tingleff & Mathiassen A/S	Tårnfalkevej 16, Postboks 511 DK 2650 Hvidovre Denmark	Tel: 31-49-17-00 Fax: 36-77-16-30
Greens	Polig. Industrial Congost 08530, La Garriga (Barcelona), Spain	Tel: 93-871-84-50 Fax: 93-871-81-80
Automocion Canarias S.A. (AUCASA)	Apartado, de Correos, num 206 Santa Cruz de Tenerife Canary Island	Tel: 922-61-13-50 Fax: 922-61-13-44
Alcorde, S.A.	Juan Rejon 67 Puerto De La Luz, Las Palmas Canary Islands	Tel: 928-27-32-00 Fax: 928-46-62-96
Su. Co. Na. S.A.	Muelle Dique Poniente P.O. Box 118, 11701 Ceuta Spain	Tel: 956-50-29-83 Fax: 956-50-47-04
The Associated Motors Company Ltd.	148, Rue D'Argens, Msida Malta	Tel: 356-333001 Fax: 356-340473
Two Wheels Ltd.	25/27 Great Ship Street Dublin 8 Ireland	Tel: (01) 782888 Fax: (01) 782807
General Automotive Co., S.A.	P.O. Box 1200, 101 73 Athens Greece	Tel: 346-5321 Fax: 346-7329